

Hard Overlay Welding for Vertical Roller ...

Durable Hardfacing of Grinding Rolls and Grinding Tables

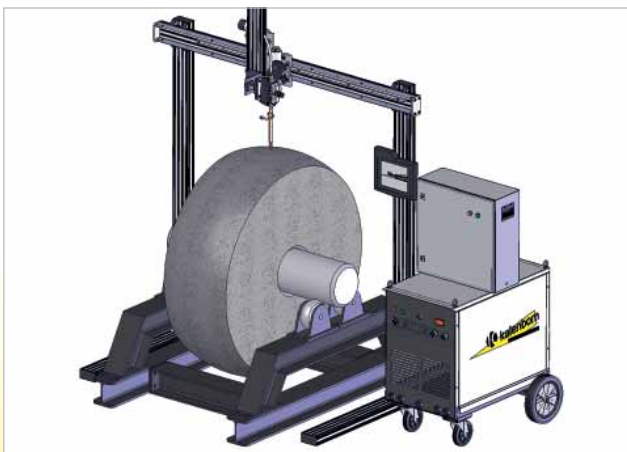

Regeneration of grinding rolls is a time-tested standard of the Kalenborn welding service



Kalenborn welding systems have been specially designed for the regeneration of grinding rolls and grinding tables

With KALMETALL-W Kalenborn provides a complete range of solutions for hard overlay welding. The following services are offered for vertical roller mills:

- hard overlay welded grinding rolls and grinding tables
- welding consumables of alloys specifically matched for use in vertical roller mills
- mobile welding system consisting of welding head, control unit and DC power supply
- welding service rendered either at the Kalenborn premises or at the mill plant site

Kalenborn Welding Services Offer the following Benefits:

- new grinding rolls and grinding plates made of hard casting with and without hardfacing to ensure long service cycles
- regeneration of grinding rolls and grinding plates to avoid the purchase of costly spare parts
- complete, cost effective services
- supply of hard casting and hard overlay welding from a single source
- excellent references in the line of welding engineering
- 80 years of practical experience in solving wear problems

Kalenborn Welding Systems for the Regeneration of Grinding Rolls and Grinding Tables in Vertical Roller Mills

The Kalenborn welding systems comprise the following components:

- one or several welded girders with one welding head each including water-cooled weld torch. The weld heads are vertically and horizontally adjustable within a specific range. The particular arrangement allows simultaneous working of one or several grinding rolls.
- Functional control with separate operating device.
- Automated flux cored wire feeding with barrel unreeling device.
- Loadable DC power unit with separate cooling unit.

The Kalenborn welding systems are specially designed for or matched to the vertical roller mill concerned, based on data collected during a site visit by Kalenborn specialists.

For reliable and quick assembly and dismantling, the Kalenborn welding systems have been split up in defined pre-assembled units. This facilitates mounting the systems in the grinding mills and removing them later. This advantage applies to both the mechanical setup and for the electrical connections.

The grinding rolls and grinding tables to be regenerated revolve under the field mounted welding torches. The weld seams are arranged next to each other after each revolution and this arrangement is continuously adjusted by means of the control unit.

Hard overlay welding is carried out by the flux cored wire process.

The welding consumables are matched to the specific application and the material to be ground.

All parameters and motions are adjustable and can be corrected and adapted during the welding process. All control functions can be implemented from the control center or the separate operating panel.

Standardized mobile welding systems are offered for use at different locations. The systems enable the regeneration of grinding rolls and grinding tables of varying dimensions. The principle of subassembled units for the mechanical and electrical installation has been adopted for these situations.

Mobile systems are offered in combination with the comprehensive Kalenborn welding services, enabling high welding quality as well as short handling periods.



Mobile hard overlay welding system and control unit of Kalenborn

Electrical Equipment

A DC unit equipped with separate water cooling unit is used as power source. This device is especially suited for hard overlay welding operations in vertical roller mills combined with preset setpoint selection.

The DC power unit has the following features:

- standard mains voltage, 3 x 400 V at 50 Hz
- weld voltage infinitely variable
- preset weld parameters being constant within +/- 1% at main power fluctuations of +/- 10%
- emergency shutoff upon unexpected stopping of the grinding roll and/or grinding table being regenerated
- good ignition properties and steady arc to warrant a consistent welding process
- digital indication of weld current and weld voltage
- integrated reactive power compensation for connection to a 63 A power receptacle
- dust-proof electronic unit
- chassis with casters, wheels and jack rings

Advantages

Kalenborn's services for the hard overlay welding of grinding rolls and grinding tables of vertical roller mills is highlighted by the following advantages:

- complete service for almost any application
- supply of specially adapted weld systems for the vertical roller mill concerned
- time-proven technique to ensure trouble-free continuous operation
- high overlay welding performance up to 10 kg/hr for each welding torch
- handling of all maintenance measures as well as short-term spare part supply by Kalenborn
- supply of welding consumables to ensure maximum product quality
- assistance given by Kalenborn weld specialist to work done on the site or complete handling of the jobs by Kalenborn welding service
- assured high weld quality utilizing the comprehensive Kalenborn welding service



DC power supply system of Kalenborn

Kalenborn Welding System for Grinding Tools: Time-Proven Use of KALMETALL-C and KALMETALL-W

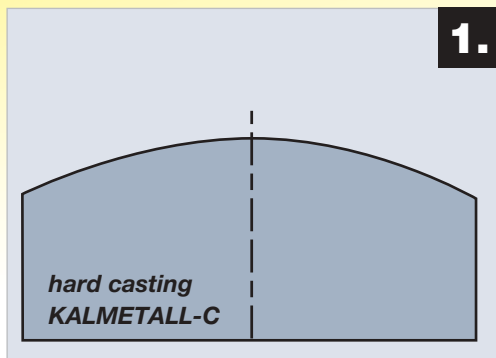

1.
KALMETALL-C

- Grinding tool cast of KALMETALL-C hard casting

Advantages:

- good service cycles

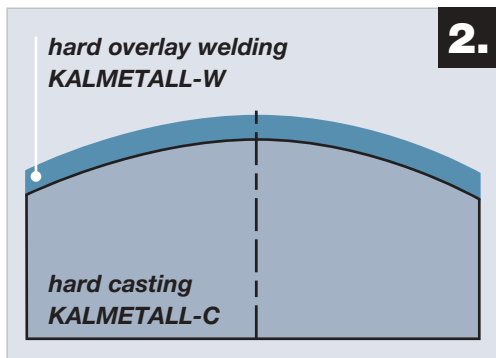

2.
KALMETALL-C and KALMETALL-W

- Grinding tool cast of KALMETALL-C hard casting
- 3-pass overlay made of KALMETALL-W hard overlay welding

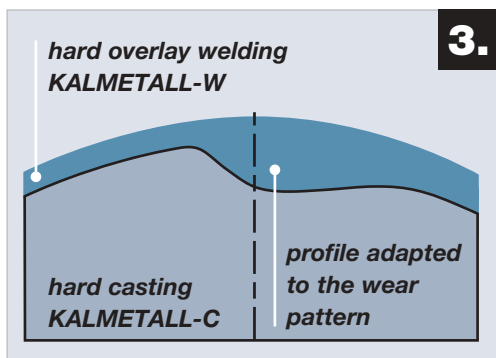

3.
Advantages:

- long service cycles
- better filling properties
- high utilization of the basic cast body

3.
KALMETALL-C, KALMETALL-W with anti-wear profile

- Grinding tool cast of KALMETALL-C hard casting with profile adapted to the wear pattern typical of the grinding mill
- Depositing the anti-wear profile by way of KALMETALL-W hard overlay welding

Advantages:

- very long service cycles
- improved material filling properties
- grinding rolls have been matched to the specific wear suffered by the mill concerned
- high utilization of the basic cast body
- low repair cost

Info Hartauftragschweißung für Vertikalrührten - GB - 2000 - K/PE - 08/09 - © 2009 Kalenborn Kalprotect GmbH & Co. KG - Abacher Str. 50 - D-53560 Velleichschoss - Germany

Kalenborn Kalprotect

Tel. +49(0) 26 45.18-0

Fax +49(0) 26 45.18-112/180 (International)

kalenborn@kalenborn.de

www.kalenborn.de



The Wear Protection People